

Acclaim III Recessed Fluorescent Luminaires ATEX

INSTALLATION, OPERATION AND MAINTENANCE INSTRUCTIONS

Important: Please read these instructions carefully before installing or maintaining this equipment. Good electrical practices should be followed at all times and this data should be used as a guide only.



STANDARD - M300 CEILING

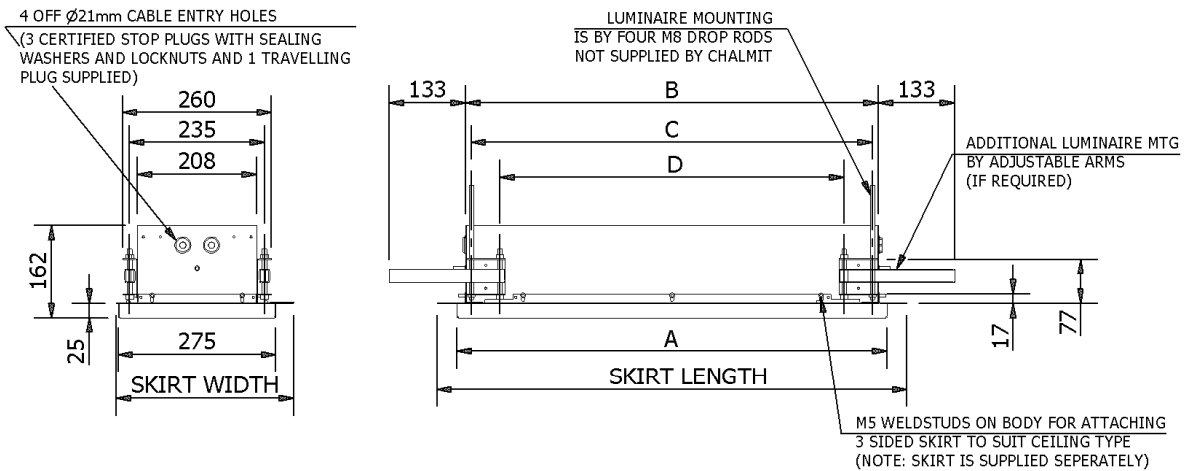

MODEL	A	B	C	D	SKIRT LENGTH	SKIRT WIDTH	CUT OUT SIZES
2X18W	750	720	700	600	820	309	800(L) X M300 TILE WIDTH
2X36W	1365	1335	1315	1215	1435	309	1415(L) X M300 TILE WIDTH

/PC SOLID PLANK CEILING

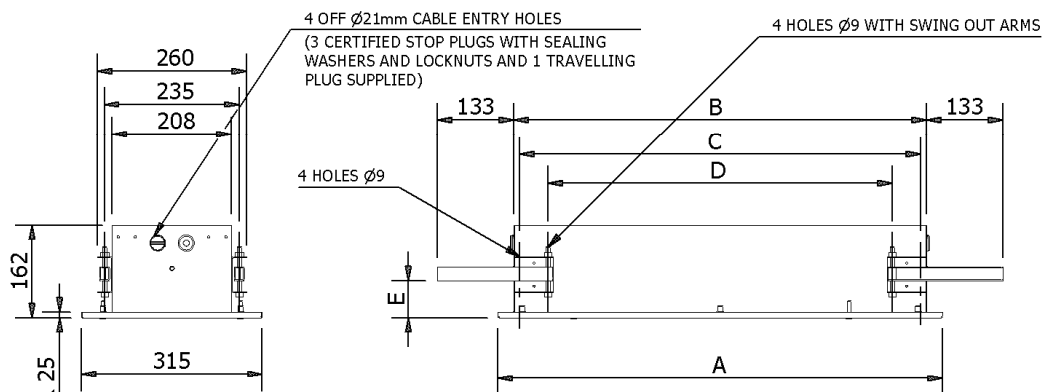

MODEL	A	B	C	D	E 10mm COVER	E 25mm COVER	CUT OUT SIZES
2X18W	775	720	700	600	35 TO 70	20 TO 55	300 X 740
2X36W	1390	1335	1315	1215	"	"	300 X 1355



0.0 Specification	
Type Of Protection	Ex eqm Increased safety, Powder filling, Encapsulation
Protection Standards	EN 50014, EN 50017, EN50019, EN 50028, EN 50281-1-1.
Area Classification	Zone 1 and 2 areas to EN 60079-10-1, Zone 21 and 22 areas to EN 60079-10-2.
Installation	EN 60079-14
Certificate	EC- Type Examination Certificate Baseefa04ATEX0286
Equipment Coding	Ex eqm IIC T4 (-20 to +45°C Insulated, +55°C Uninsulated)
ATEX Coding	Ⓜ II 2GD T95°C
Ingress Protection	IP65 to EN 60529
CE Mark	<p>The CE marking of this product applies to "The Electrical Equipment (Safety) Regulations 2006", "The Electromagnetic Compatibility Regulations 2004", the "Waste Electrical and Electronic Equipment Regulations 2006" and the "Equipment and Protective Systems intended for use in Explosive Atmospheres Regulations 1996". [This legislation is the equivalent in UK law of EU directives 2014/35/EU, 2014/30/EU, 2012/19/EU and 2014/34/EU respectively].</p> <p>The Equipment is declared to meet the provisions of the ATEX directive (2014/34/EU) by reason of the EC Type Examination and compliance with the Essential Health and Safety Requirements.</p> <p>M Poutney Technical Manager</p>

SPECIAL CONDITIONS FOR SAFE USE
None

1.0 Introduction – Acclaim ATEX Model

This installation leaflet covers the range of ATEX Acclaim recessed luminaire models with the Ex q control gear which has EOL circuitry and electronic safety sensor. These luminaires are mainly used in harsh environments and are constructed using a painted steel body and polycarbonate diffuser. Refer to the current catalogue for information on product references. The range is available for use with T8 bi-pin lamps to IEC81. The appropriate lamp cap should be specified when ordering. The integrated unit consists of a mains supplied ballast for supplying the fluorescent lamp.

B15 SOLAS The luminaire can be installed to interface with fire resistant ceiling systems to maintain a B15 SOLAS fire rating; the integrity of the ceiling and insulation must be maintained using suitable insulation materials. The ceiling/fitting and insulation should be continuous (without any gaps), care must be taken to maintain this classification.

1.1 Electrical Supplies

Lamps	2 x 18W	1 x 36W	2 x 36W
Voltage range AC	110-130V or 220-254V		
Voltage range DC	110-150V or 220-300V		
Frequency range Hz	47-63Hz		
Power Watts 220-254V	35W	42W	70W
Current Amps 220-254V	0.17A	0.20A	0.32A
Power Watts 110-130V	35W	42W	70W
Current Amps 110-130V	0.34A	0.40W	0.65A

The safety limit for surface temperature (T rating) is +/-10% on the rated voltage. Equipment should not be operated continuously at more than +/-10% of the rated voltage of the control gear.

Power Factor >0.98	Power is constant over voltage range.
Over voltage	400V ac for 1 min and EN 61000-4-5 > 4kV
Through Wiring	The through current rating is 16A. 4mm ² terminals are standard (6mm ² wiring can be used in the terminals in accordance with the luminaire certificate).
Tamb Storage	-40°C to +80°C
Storage	Luminaires are to be stored in cool dry conditions preventing ingress of moisture and condensation.
Lamps	The lamps used in the range can be T8 bi-pin fluorescent with G13 cap. Lamp caps are to IEC 60061, lamp dimensions and safety to IEC 61195 and lamp performance to IEC 60081. Please note that this luminaire is suitable for IEC lamps only. Do not use American specification lamps.
Fuse and MCB Ratings	It is recommended that for selection of MCBs users should consult the MCB manufacturer as this unit contains electronic control gear. MCB ratings can vary depending on the manufacturer and type and the size of the installation. The electronic control gear has nominal values of inrush current of 30A for 500µs on 230V and 45A for 350µs on 110V.
EOL Circuitry	The Acclaim III control gear has circuitry to protect against the potential effects from the end of life condition associated with fluorescent lamps in accordance with IEC 61347-2-3 and 60079-7.

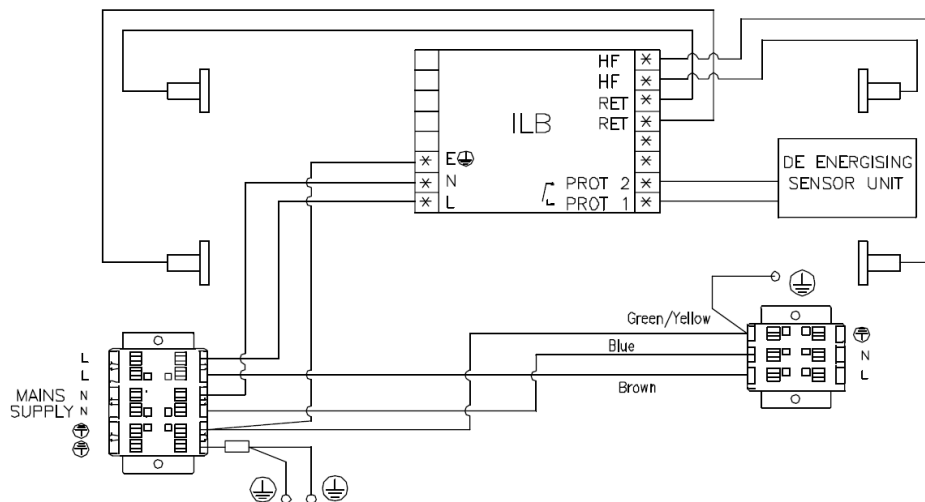

2.0 Installation and Safety

2.1 General

These instructions should be read fully and carefully before attempting to install the luminaire. For details of servicing operations, opening etc. see section 3.0.

Note: This range is available in a number of similar but distinctly different versions. Care must be taken to use the correct instructions and spares, if in doubt contact sales or product support.

Copies of these instructions should be held in a safe place for future reference. It is the responsibility of the installer to ensure that the apparatus selected is fit for its intended purpose and that the installation, operation and maintenance of the apparatus complies with applicable regulations, standards or codes of practice.

Installation should be carried out in accordance with EN 60079-14 or with a local hazardous area code of practice, whichever is appropriate. Any specific installation instructions must be referred to. Disposal instructions should be complied with.

The luminaires should be considered Class 1 to EN 60598 and effectively earthed.

The polycarbonate diffuser presents a potential source of ignition by **electrostatic electricity**. The diffuser should only be cleaned using a damp cloth. The luminaire should not be mounted very near to any probable location of fast moving stream of dry air, steam etc. which could generate a propagating brush static discharge.



Certification details on the rating plate must be verified against the application requirements before installation. The information in this leaflet is correct at the time of publication. The company reserves the right to make specification changes as required without notice.

2.1.1 Use in Combustible Dust Atmospheres

Where the equipment is used in combustible dust atmospheres reference must be made to the selection and installation standards in order that the equipment is used correctly. In particular this applies to the de-rating of surface temperature for use where dust clouds may be present. Dust layers should not be allowed to accumulate on the fitting surface and good housekeeping is required for safe operation. Dust in layers has the potential to form ignitable clouds and to burn at lower temperatures.

Refer to EN 60079-10-2 and EN60079-14 for additional details of selection, installation and maintenance.

2.2 Tools

12mm, 3mm and 4mm flat blade screwdriver and large crosshead screwdriver. Allen Key for adjusting swing out arms. Suitable spanners for installing cable glands. Pliers, knife, wire strippers/cutters.

2.4 Lamps

The lamps will run until they are worn out. New lamps should be fitted in pairs even if one appears to be still working. If the result is not satisfactory, check continuity to the ballast. If still no result, check the continuity to the lampholders after disconnecting leads from ballast. If no fault found replace ballast. If still no result, disconnect the connection to the sensor. If the lamps light this would indicate a faulty sensor, see 3.6, but as this is most unlikely, check all connections before replacing.

2.5 Mounting

Luminaires should be installed where access for maintenance is practical and in accordance with lighting design information. Refer to the note in 2.1 concerning electrostatic charge.

When mounting of ceiling support channels, via side arms or adjustable side arms, they must be secured onto channels by fixing screws. When B15 fire rating is a requirement all conditions stated by the ceiling manufacturer and Chalmit must be met.

As an insulated recessed unit the Tamb rating is 45°C as a non-insulated unit in a plain recess the Tamb rating is 55°C. Therefore the usual mounting in a metal ceiling with 75 mm of insulation at 45°C is acceptable. If the temperature in an installation is continuously at the limiting level the duration will be reduced and the self-testing will be delayed.

2.6 Cabling and Cable Glands

The temperature conditions at the supply cable entry point are such that 70°C (ordinary PVC) cable can be used. Cable glands and sealing plugs must have ATEX component approval. The cable and gland assembly when installed must maintain a minimum IP54 rating.

Four entries are provided. Three entries are fitted with suitably approved blanking plugs, the fourth entry with a transit plug. M20 x 1.5 entries are standard, other sizes are available on request.

2.7 Electrical Connections and Testing

If work other than re-lamping is to be done on any luminaire already connected to the electrical system, the luminaire must be isolated from the system.

Access for the cabling is via removal of front cover and lamp tray. The front cover is secured using 6/10 off M6 captive screws; care to be taken as there is no suspension with this only the earth connection. The lampholder tray is secured by M5 screws and keyhole slots, with chain suspension allowing the tray to swing down, giving access to terminal blocks.

Luminaires are supplied suitable for looping and through wiring. Screw type or screw-less "cage clamp" terminals are fitted in the range of luminaires. Mains terminal blocks are marked L N Earth.

Luminaires can also be supplied with three phase wiring to special order. The marking is L1 L2 L3 N Earth.

An earth terminal is fitted to the cover and must be reconnected prior to re-affixing the cover to the body.

The maximum amount of insulation allowed beyond the throat of the terminal is 1mm. The normal method of insulation testing is to connect Live and Neutral together and test between this point and Earth to prevent the risk of damage to the electronic control gear. However, if this is not possible luminaires can be tested with an insulation tester that complies with IEC 364 or BS 7671 with a maximum output current of 1mA and output voltage of 500V dc. (Units damaged by incorrect insulation testing can be detected).

Before completing the wiring, ensure that all the connections are correctly introduced into place before reassembling the luminaire. New lamps should be fitted.

3.0 Servicing and Operation

The bi-pin luminaire incorporates an electronic safety de-energiser for maximum reliability. The electronic sensor is operated by the actuating plate on the diffuser. This provides for the safe opening and carrying out of re-lamping.

Safe servicing behind the gear tray requires the mains supply to be isolated.

3.1 Opening and Closing



The front cover is secured using 6/10 off M6 captive screws; care to be taken to avoid damage, the cover will hang down via two nylon straps with clip release at each end attached to the gasket blade and the body chassis.

3.2 Fitting lamps and Re-Lamping

IMPORTANT - If the luminaire is maintained with the power on, the lamps will go out when the cover is opened. If this does not happen there is a fault. Do not remove the lamps. The control gear will be damaged if the lamps are removed without being de-energised and there is an ignition risk. This could occur if the sensor arrangement is faulty or has been defeated. The luminaire must be de-energised the control gear checked and electronic sensor assembly must be replaced if faulty. The lamps will run until they are worn out. New lamps should be fitted in pairs even if one appears to be still working. If the result is not satisfactory, check continuity to the ballast. If still no result, check the continuity to the lampholders after disconnecting leads from ballast. If no fault found replace ballast. If still no result, disconnect the connection to the sensor. If the lamps light this would indicate a faulty sensor, see 3.6, but as this is most unlikely, check all connections before replacing.

Lamps which are not operating or appear dim should be replaced as soon as practical. The control gear is designed to withstand end of life conditions of lamps. The bi-pin lamps are fitted in lampholders with a rotating section. The lamp must be pushed firmly down into the lampholder and rotated 90°. The contact is biased to remain in the 90° position. If the lamp does not rotate, check that it is completely positioned into the lampholder. Before inserting bi-pin lamps ensure the lamp pins are not damaged or slack in the end cap.

3.3 Releasing the Reflector/Gear Tray

Loosen the four fixing screws retaining the reflector/gear tray far enough for it to slide over keyhole slots. The tray will hang on the retaining cords without stressing the wiring between body and tray. Replace in reverse order.

3.4 Servicing Behind the Gear Tray

The release of the gear tray exposes live mains terminals. Any work behind the gear tray requires that the supply is isolated to avoid ignition risk and damage to components.

3.5 Replacement of Ballast

The ballast contains no serviceable parts. Should it be found necessary to replace the ballast, the following procedure should be adopted:

Ensure that the luminaire is isolated from the mains supply.

Remove gear tray from body and swing down as previously explained. Remove the ballast from the tray. Ballasts use locking tab connectors which are released when the black cover sleeve is pulled away axially. When replaced a 'click' will be heard as the lock locates. On no account should the quick release connectors be replaced with proprietary items.

Disconnect the leads to the ballast, note the connections.

3.6 Replacement of sensor

It is very unlikely that this assembly will need replacement other than as a result of mechanical damage.

Isolate the mains. Disconnect the sensor and note the connections. Undo the two screws and replace the unit using the nuts from the old unit. Reconnect and carefully check the connections before re-energising.

4.0 Routine Maintenance

Visual tests and checks should be carried out at intervals described by the appropriate regulations, EN 60079-17, and should include the following:

Check that the lamps are working and for blackening at the lamp ends, this is a good indication of ageing.

- Check for mechanical damage/corrosion.
- Check connections, fixings, glands and plugs.
- Check for undue accumulations of dust, dirt or moisture.
- Check for unauthorised modifications.

Periodic inspection of the enclosure seal should be carried out to ensure that the seal is sound. If the luminaire has been subject to abnormal conditions, for example, severe mechanical impact or chemical spillage, it must be de-energised until it has been inspected by an authorised and competent person.

5.1 Cleaning



The body of the luminaire may be cleaned with a mild solution of household detergent and water, after cleaning the body should be washed and wiped with clean water. The diffuser should not be polished or wiped with a dry cloth as a risk of ignition due to electrostatic discharge may result. Cleaning of the diffuser with any chemical or hydrocarbon solvent based cleaner may result in severe damage.

6.0 Disposal of Material
General

Disposal of Material

Any disposal must satisfy the requirements of the WEEE directive [2012/19/EU] and therefore must not be treated as commercial waste.

6.1 Lamps

Fluorescent lamps in modest quantities are not "special waste". They should be broken up in a container to avoid injury, avoid inhaling dust.

Important: Do not incinerate lamps.

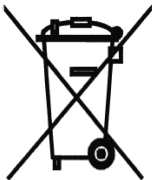

To comply with the Waste Electrical and Electronic Equipment directive 2012/19/EU the apparatus cannot be classified as commercial waste and as such must be disposed of or recycled in such a manner as to reduce the environmental impact.

Chalmit Lighting is a leading supplier of Hazardous Area lighting products

	CHALMIT LIGHTING PO Box 5575 Glasgow, G52 9AP Scotland	
Telephone: +44 (0) 141 882 5555 Fax: +44 (0) 141 883 3704 Email: info@chalmit.com Web: www.chalmit.com	Registered No: 669157 Registered Office: Cannon Place 78 Cannon Street London EC4N 6AF UK	

For technical support, please contact: techsupport@chalmit.com

Note: Chalmit Lighting reserves the right to amend characteristics of our products and all data is for guidance only.



	EU-Declaration of conformity		
	UE-Déclaration de conformité		
	EU-Konformitätserklärung		
Manufacturer	Chalmit	Address	388 Hillington Road, Glasgow. G52 4BL Scotland UK
Product	Acclaim III Recessed Luminaires.		
EC - Type Examination Certificate	Baseefa04ATEX0286		
Notified Body	SGS FIMKO OY 0598		
ATEX Coding	II 2GD	ATEX Classification	Group II Category 2 GD
Equipment Coding	Ex eqm IIC T4 T95°C		
Ingress Protection	IP65		
The technical basis, with respect to equivalence of			
La base technique, en ce qui concerne l'équivalence de			
Die technische Grundlage hinsichtlich der Normen			
Protection Standards EN 50014, EN 50017, EN50019, EN50028, EN 50281-1-1			
Area Classification EN 60079-10-1, EN 60079-10-2.			
of compliance with the EHSRs is valid as there are no changes which materially affect the state of technological progress of the product.			
en conformité avec les EESS est valide puisqu'il n'y a aucun changement qui affecte matériellement l'état de l'évolution technologique du produit.			
zur Erfüllung der GSGA ist gegeben, da keine Änderungen erfolgt sind, die einen Einfluss auf den technischen Stand des Produkts haben.			
Terms of the directive:		Standard & Date Certified to	Standards Date Declared to
Prescription de la directive:		Standard & date certifiée à	Normes date Déclaré
Bestimmungen der Richtlinie:		Standard & Datum Zertifiziert nach	Standards Datum erklärt
2014/34/EU	Equipment and protective systems intended for use in potentially explosive atmospheres.	EN 50014: 1997 Amd 1&2 EN 50017: 1998	
2014/34/UE	Appareils et les systèmes de protection destinés à être utilisés en atmosphères potentiellement explosibles.	EN 50019: 2000	
2014/34/EU	Geräte und Schutzsysteme zur bestimmungsgemäßen Verwendung in explosionsfähigen Bereichen.	EN 50028:1987 EN 50281-1-1: 1998	
2014/30/EU	Electromagnetic compatibility	EN 55015 : 2013	
2014/30/UE	Compatibilité électromagnétique	EN 61547 : 2009	
2014/30/EU	Elektromagnetische Verträglichkeit	EN 61000-3-2 : 2014	
2014/35/EU	Low voltage equipment	EN 60598-1 : 2015	
2014/35/UE	Équipements électriques à bas voltage	EN 60598-2-2 : 2015	
2014/35/EU	Niederspannungsgeräte / -systeme	EN 60529 : 1992	
2012/19/EU	Waste of electrical and electronic equipment		
2012/19/UE	Déchets d'équipements électriques et électroniques		
2012/19/EU	Entsorgung der elektrischen und elektronischen Geräte / Systeme		
2011/65/EU	RoHS II Directive		



On behalf of the Chalmit, I declare that, on the date the equipment accompanied by this declaration is placed on the market, the equipment conforms to all technical and regulatory requirements of the above listed directives.

En tant que représentant du fabricant Chalmit, je déclare qu'à la date où les équipements accompagnant cette déclaration sont mis sur le marché, ceux-ci sont conformes à toutes les dispositions réglementaires et techniques des directives énumérées ci-dessus.

Hiermit bestätige ich, im Namen von Chalmit, dass am Tag der Lieferung des Produkts/der Produkte zusammen mit dieser Erklärung das Gerät/die Geräte alle technischen und regulativen Anforderungen der oben aufgeführten Direktiven erfüllt.

Name and Date Mark Poutney 01/01/2021
Nom et Date
Name und Datum

Technical Manager
Directeur technique
Technischer Leiter

Quality Assurance Notification by: **SGS FIMKO OY**
Notification d'assurance qualité par: **0598**
Qualitätssicherungsnotifikation durch:

Quality Management System Accreditation:
Système de Management Qualité Accréditation:
Qualitätsmanagementsystem Akkreditierung:
Environmental Management System.
Système de gestion de l'environnement.
Umwelt kontroll system.
Certificate No./Certificat N°/Zertifikat Nr.

ISO 9001

ISO 14001
by/par/durch
Lloyd's Register
LRQ 4005876